

Copying of this document and giving it to others, and the use or communication of the contents thereof, are forbidden without express authority. All rights reserved.

Weitergabe und Vervielfältigung dieser Unterlage, sowie Verwertung und Mitteilung ihres Inhalts nicht gestattet, soweit nicht ausdrücklich zugestanden. Alle Rechte vorbehalten

1 2 3 4 5 6 7 8

A  
B  
C  
D  
E  
F

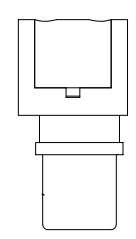
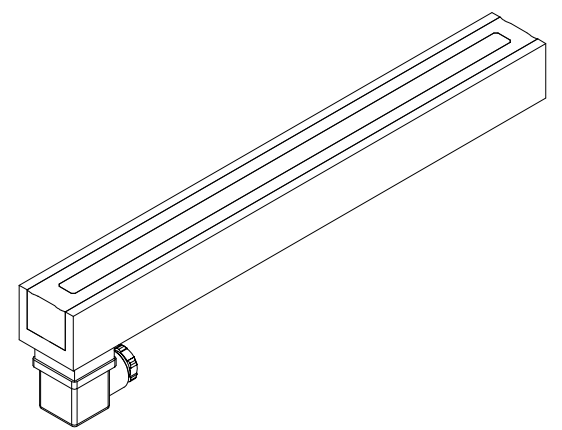
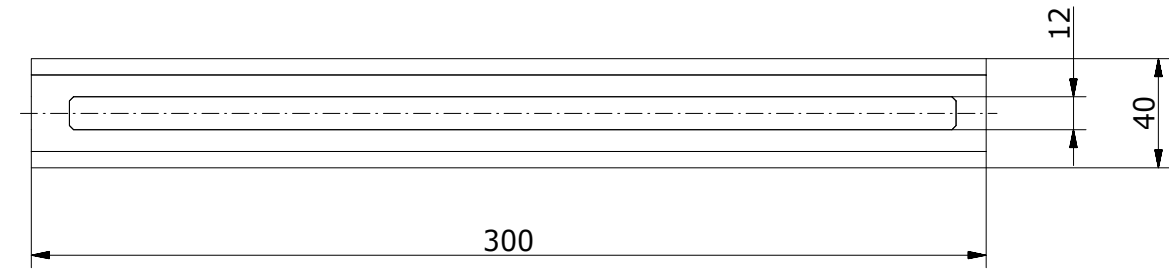
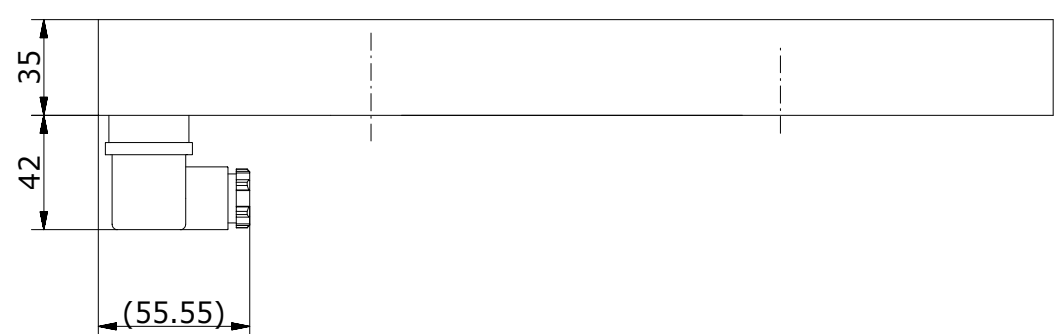
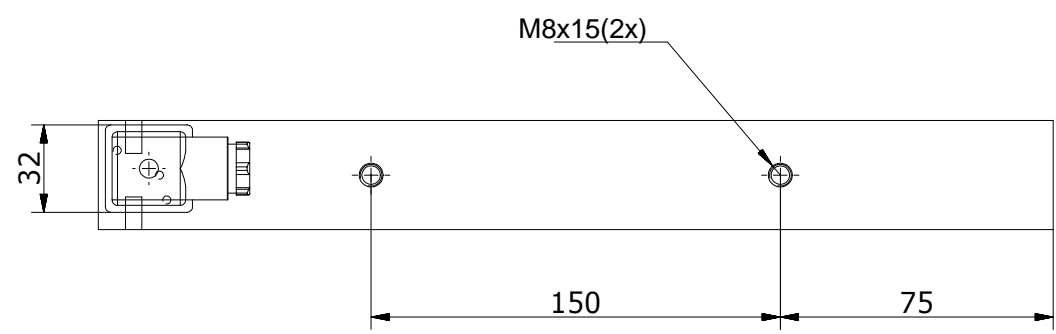

**NOTE:**  
 1.24V; 120W  
 2.DUTY 10%  
 3.0mm stroke, force>4000N

 <b>MMT</b> MANNEL MAGNETTECHNIK		Maße in mm Dimensions in millimeters 	Zul. Abw. f. Maße ohne Toleranzang. General tolerances ISO 2768-Km	Fertigungszustand finished cond. 	Maßstab Scale 1:2	Menge Quantity 1
		2011 Datum Date		Name Name		Benennung/Designation <b>PE- Magnet 24VDC          300x40x35mm</b>
		Bearb. Drawn 29.08.11		R. Mannel		
		Gepr. Check 29.08.11		C. Franke		
		Norm Appr.				
				Sachnummer/Part-No. <b>4443135</b>		Blatt Sheet 1 von of 1
		Ursprung Source		MegaCAD		

1 2 3 4 5